



MURATORI

**TIPO-TYPE-TYP
MTL 2**

CATALOGO RICAMBI
Catalogue Pièces Detachées
Ersatzteilkatalog
Spare Parts Catalogue
Catálogo Recambios

EDIZIONE 07/2013

Per ordinare parti di ricambio specificare:

- tipo e matricola della macchina (apposti sulla macchina o sui documenti di acquisto);
- numero del riferimento del pezzo nel disegno (Pos.), numero della tavola (Tav.) e numero di codice

N.B.: le indicazioni destro o sinistro vengono date guardando la macchina da dietro.

Pour les commandes de pièces de rechange veuillez spécifier:

- *type et numéro de série de la machine (indiqués sur la machine et sur le bon d'achat);*
- *numéro de référence du pièce sur le plan (Pos.), numéro du plan (Tav.) et numéro de code (codice)*

N.B.: *les indications droite ou gauche sont données en regardant la machine par derrière.*

Zum Bestellen von Ersatzteilen folgendes angeben:

- *Typ und Serien-Nr. der Maschine (zu finden auf der Maschine oder der Einkaufspapieren);*
- *Bezug-Nr. des Ersatzteils auf der Zeichnung (Pos.), Zeichnungsnummer (Tav.) und Kodenummer (codice)*

N.B.: *Die Angaben rechts und links verstehen sich so, dass man hinter der Maschine steht.*

When ordering spare parts specify:

- machine type and serial number (found on the machine or on the purchasing documents);
- reference number of the part on the relative drawing (Pos.) number of the drawing (Tav.) and part number (codice)

N.B.: right-hand or left-hand indications are made by viewing the machine from the rear.

TAV. 1.0

GRUPPO TELAIO
ENSEMBLE CHASSIS
SATZ FÜR RAHMEN
KIT FOR FRAME

TAV. 2.0

GRUPPO TRASMISSIONE ROTORE
ENSEMBLE TRANSMISSION ROTORS
SATZ FÜR DEN ROTARONTRIEB
KIT FOR THE ROTOR TRANSMISSION

TAV. 3.0

GRUPPO RULLO POSTERIORE
ENSEMBLE ROULEAU ARRIERE
SATZ HINTERE WALZE
KIT REAR ROLLER

TAV. 4.0

GRUPPO MOLTIPLICATORE
ENSEMBLE MULTIPLICATEUR
SATZ FÜR GETRIEBE
KIT FOR GEAR BOX

TAV. 5.0

ATTACCO 3-PUNTI E SPOSTAMENTO
ATTELAGE 3-POINTS ET DEPLACEMENT
3-PUNKT-ANSCHLUSS UND VERSCHIEBUNG
3-POINT-HITCH AND OFFSET SYSTEM

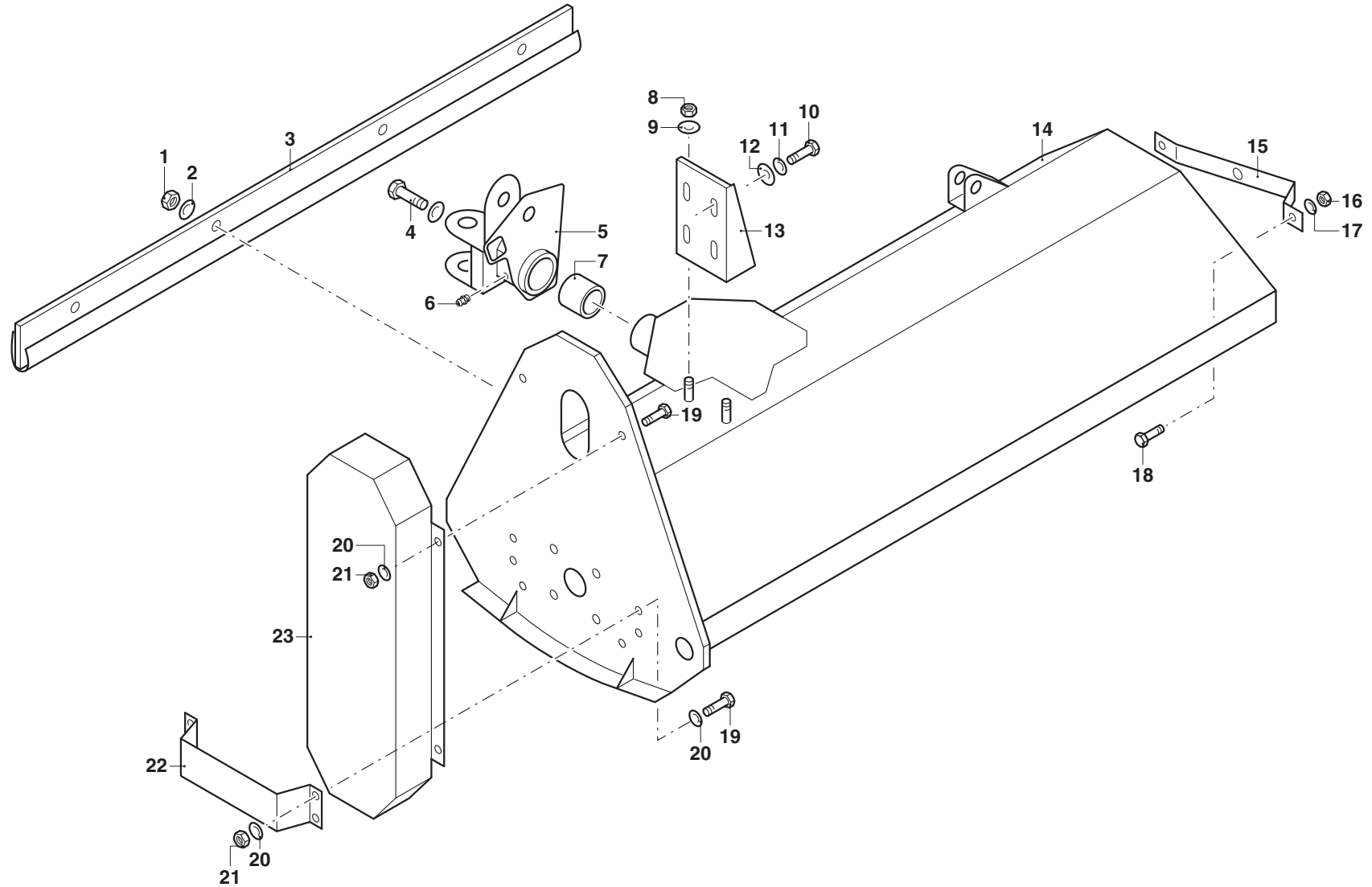

MURATORI MTL 2

TAV. 1.0

POS.	N° CODICE	Q.	DESCRIZIONE	DESIGNATION	BENENNUNG	DESCRIPTION	DESIGNAZIONE	Da matr. De nr. serie Vom Seriennr. From serial nr.	Fino matr. Jusqu'au nr. serie Bis Seriennr. Up to serial nr.
1	62010400		DADO	ECROU	MUTTER	NUT	M 10x1,5 AUTOBLOCC.		
2	61004900		RONDELLA	RONDELLE	SCHEIBE	WASHER	PIANA Ø 10 UNI 6592		
3	39311700	1	BANDELLA	BANDE	BAND	STRAP	130		
3	39311800	1	BANDELLA	BANDE	BAND	STRAP	155		
4	60045000	1	VITE	VIS	SCHRAUBE	SCREW			
5	40286500	1	STAFFA	BRIDE	BUEGEL	BRACKET			
6	64000200	1	INGRASSATORE	GRAISSEUR	SCHMIERNIPPEL	GREASE FITTING	M 6x1		
7	32195000	1	BOCCOLA	DOUILLE	BUECHSE	BUSHING			
8	62010600	2	DADO	ECROU	MUTTER	NUT	M 12x1,75 AUTOBLOCC.		
9	61007500	2	RONDELLA	RONDELLE	SCHEIBE	WASHER	PIANA Ø 12x36		
10	60023000	4	VITE	VIS	SCHRAUBE	SCREW	TE 12x30 UNI 5739		
11	61010300	4	RONDELLA	RONDELLE	SCHEIBE	WASHER	ELASTICA Ø 12 UNI 1751		
12	61007500	4	RONDELLA	RONDELLE	SCHEIBE	WASHER	PIANA Ø 12x36		
13	40301300	1	SUPPORTO	SUPPORT	HALTERUNG	SUPPORT			
14	41124500	1	TELAIO	CHASSIS	RAHMEN	FRAME	130		
14	41124600	1	TELAIO	CHASSIS	RAHMEN	FRAME	155		
15	39311500	1	PROTEZIONE DX	PROTECTION (D)	SCHUTZ (RECHTS)	GUARD (RH)			
16	62010400		DADO	ECROU	MUTTER	NUT	M 10x1,5 AUTOBLOCC.		
17	61004900		RONDELLA	RONDELLE	SCHEIBE	WASHER	PIANA Ø 10 UNI 6592		
18	60017900		VITE	VIS	SCHRAUBE	SCREW	TE 10x25 UNI 5739		
19	60022800		VITE	VIS	SCHRAUBE	SCREW	TE 8x20 UNI 5739		
20	61004700		RONDELLA	RONDELLE	SCHEIBE	WASHER	PIANA Ø 8 UNI 6592		
21	62010200		DADO	ECROU	MUTTER	NUT	M 8x1,25 AUTOBLOCC.		
22	39311600	1	PROTEZIONE SX	PROTECTION (G)	SCHUTZ (LINKS)	GUARD (LH)			
23	40286200	1	CARTER	CARTER	SCHUTZABDECKUNG	CASING			

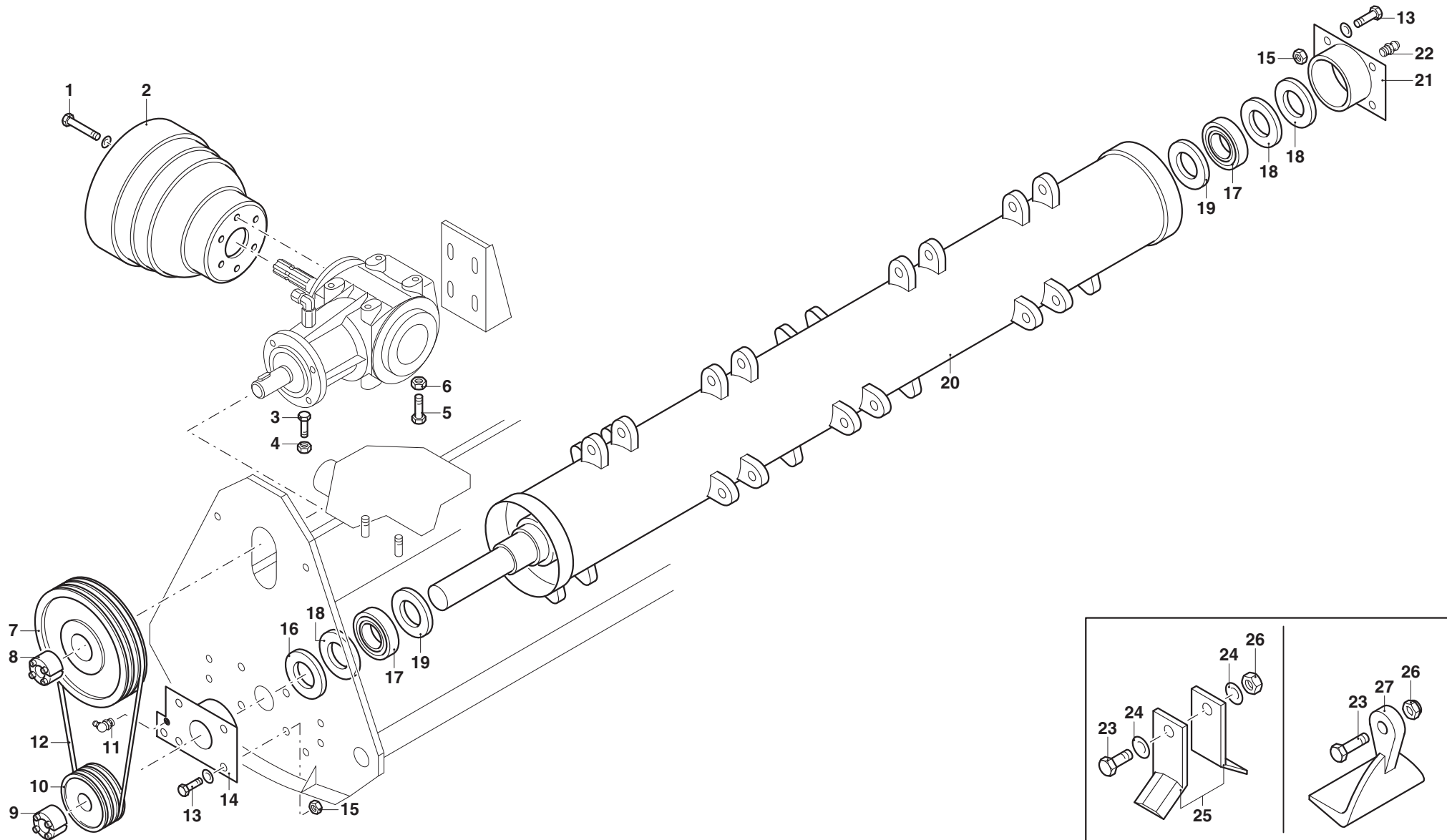

MURATORI MTL 2

TAV. 2.0

POS.	N° CODICE	Q.	DESCRIZIONE	DESIGNATION	BENENNUNG	DESCRIPTION	DESIGNAZIONE	Da matr. De nr. serie Vom Seriennr. From serial nr.	Fino matr. Jusqu'au nr. serie Bis Seriennr. Up to serial nr.
1	60015100	4	VITE	VIS	SCHRAUBE	SCREW	TE 8x16		
2	68114500	1	PROTEZIONE	PROTECTION	SCHUTZ	GUARD			
3	60022200	1	VITE	VIS	SCHRAUBE	SCREW	TE 10x50 UNI 5739		
4	62007000	2	DADO	ECROU	MUTTER	NUT	M 10x1,5 UNI 5588		
5	60035500	2	VITE	VIS	SCHRAUBE	SCREW	TE 12x50 UNI 5739		
6	62009100	2	DADO	ECROU	MUTTER	NUT	M 12x1,75 UNI 5588		
7	68114200	1	PULEGGIA	POULIE	RIEMENSCHLEIBE	PULLEY			
8	68114400	1	CALETTATORE	DOUILLE DE SERRAGE	SPANNBUCHSE	LOCKING DEVICE	33x65		
9	68084100	1	CALETTATORE	DOUILLE DE SERRAGE	SPANNBUCHSE	LOCKING DEVICE	35x65		
10	68114300	1	PULEGGIA	POULIE	RIEMENSCHLEIBE	PULLEY			
11	64003600	1	INGRASSATORE	GRAISSEUR	SCHMIERNIPPEL	GREASE FITTING			
12	68113300	3	CINGHIA	COURROIE	KEILRIEMEN	BELT			
13	60017900	8	VITE	VIS	SCHRAUBE	SCREW	TE 10x25 UNI 5739		
14	40286300	1	SUPPORTO SX	SUPPORT (G)	HALTERUNG (LINKS)	SUPPORT (LH)			
15	62010400	4	DADO	ECROU	MUTTER	NUT	M 10x1,5 AUTOBLOCC.		
16	66001600	1	ANELLO TENUTA	JOINT D'ETANCHEITE	DICHTUNGSRING	JUNT RING	35x52x7		
17	67020800	2	CUSCINETTO	ROULEMENT	LAGER	BEARING	1208		
18	68113400		SPESSORE	EPAISSEUR	DISTANZRING	SPACER	79x71x2		
19	66010700	2	ANELLO TENUTA	JOINT D'ETANCHEITE	DICHTUNGSRING	JUNT RING	50x80x10		
20	42080100	1	ROTORE	ROTOR	ROTOR	ROTOR	130		
20	42080200	1	ROTORE	ROTOR	ROTOR	ROTOR	155		
21	40286400	1	SUPPORTO DX	SUPPORT (D)	HALTERUNG (RECHTS)	SUPPORT (RH)			
22	64000200	1	INGRASSATORE	GRAISSEUR	SCHMIERNIPPEL	GREASE FITTING	M 6x1		
23	60044800		VITE	VIS	SCHRAUBE	SCREW			
24	61005000		RONDELLA	RONDELLE	SCHEIBE	WASHER	PIANA Ø 12		
25	12020200		COLTELLO	COUTEAU	MESSER	KNIFE			

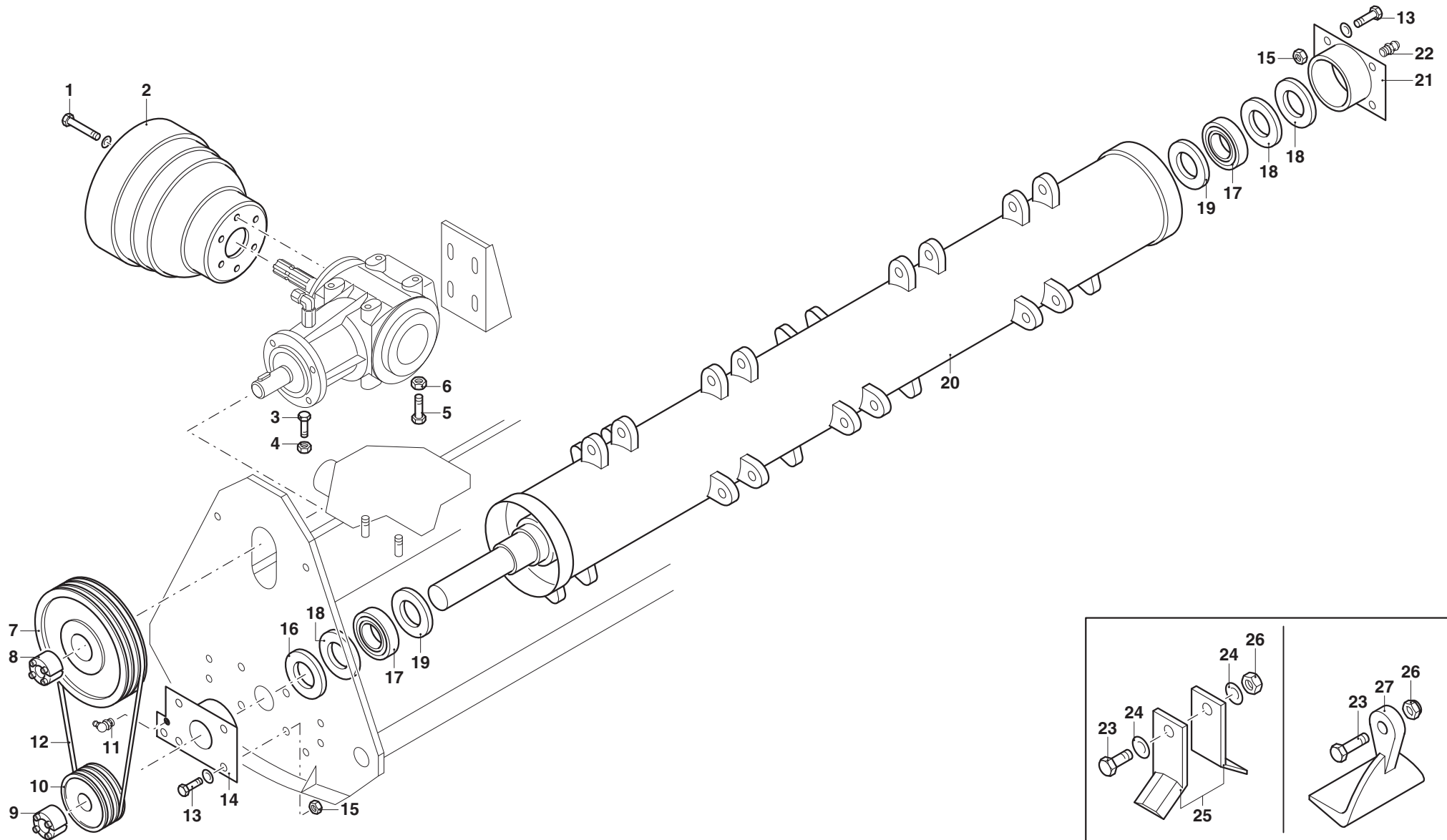

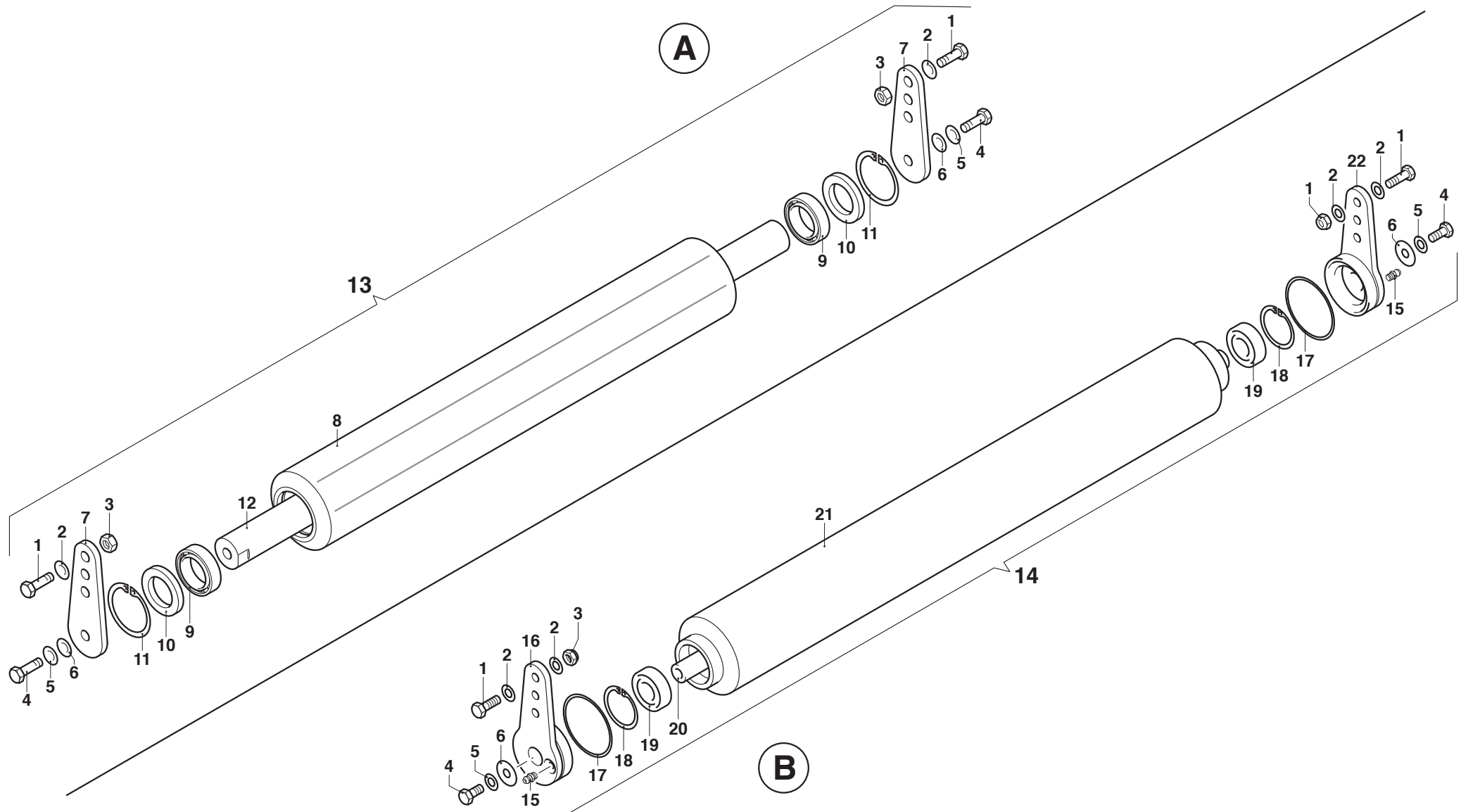

MURATORI MTL 2

TAV. 3.0

POS.	N° CODICE	Q.	DESCRIZIONE	DESIGNATION	BENENNUNG	DESCRIPTION	DESIGNAZIONE	Da matr. De nr. serie Vom Seriennr. From serial nr.	Fino matr. Jusqu'au nr. serie Bis Seriennr. Up to serial nr.
1	60021300	8	VITE	VIS	SCHRAUBE	SCREW	TE 10x30 UNI 5739		
2	61004900	12	RONDELLA	RONDELLE	SCHEIBE	WASHER	PIANA Ø10 UNI 6592		
3	62010400	8	DADO	ECROU	MUTTER	NUT	M 10x1,5 AUTOBLOCC.		
4	60020400	4	VITE	VIS	SCHRAUBE	SCREW	TE 12x25 UNI 5739		
5	61010300	4	RONDELLA	RONDELLE	SCHEIBE	WASHER	ELASTICA Ø12 UNI 1751		
6	61007500	4	RONDELLA	RONDELLE	SCHEIBE	WASHER	PIANA Ø12 UNI 6593		
7	39311900	2	COPPIA STAFFE	COUPLE BRIDES	BUEGELPAAR	BRACKETS COUPLE			
8	42077600	1	RULLO LIVELLATORE	ROULEAU ARRIERE	HINTERESTUETZWALZE	REAR ROLLER	130		
8	42077700	1	RULLO LIVELLATORE	ROULEAU ARRIERE	HINTERESTUETZWALZE	REAR ROLLER	155		
9	67008300	2	CUSCINETTO	ROULEMENT	LAGER	BEARING	6205 2RS		
10	61011200	2	RONDELLA	RONDELLE	SCHEIBE	WASHER			
11	63007700	2	ANELLO ELASTICO	ARRETOIR	SPANNRING	SNAP-RING			
12	31094900	1	PERNO	PIVOT	BOLZEN	PIN	130		
12	31098500	1	PERNO	PIVOT	BOLZEN	PIN	155		
13	45163800	1	KIT RULLO LIVELLATORE	KIT ROULEAU ARRIERE	HINTERESTUETZWALZE SATZ	REAR ROLLER KIT	130		
13	45163900	1	KIT RULLO LIVELLATORE	KIT ROULEAU ARRIERE	HINTERESTUETZWALZE SATZ	REAR ROLLER KIT	155		
14	45172900	1	KIT RULLO LIVELLATORE	KIT ROULEAU ARRIERE	HINTERESTUETZWALZE SATZ	REAR ROLLER KIT	130		
14	45173000	1	KIT RULLO LIVELLATORE	KIT ROULEAU ARRIERE	HINTERESTUETZWALZE SATZ	REAR ROLLER KIT	155		
15	64000200	2	INGRASSATORE	GRAISSEUR	SCHMIERNIPPEL	GREASE FITTING	6x1 DIRITTO		
16	40312400	1	SUPPORTO SX	SUPPORT (G)	HALTERUNG (LINKS)	SUPPORT (LH)			
17	66019400	2	ANELLO TENUTA	JOINT D'ETANCHEITE	DICHTUNGSRING	JUNT RING	O.R. 6262		
18	63007700	2	ANELLO ELASTICO	ARRETOIR	SPANNRING	SNAP-RING	Ø52 I		
19	67012700	2	CUSCINETTO	ROULEMENT	LAGER	BEARING	6205		
20	31094900	1	PERNO	PIVOT	BOLZEN	PIN	130		
20	31098500	1	PERNO	PIVOT	BOLZEN	PIN	155		
21	42082500	1	RULLO LIVELLATORE	ROULEAU ARRIERE	HINTERESTUETZWALZE	REAR ROLLER	130		

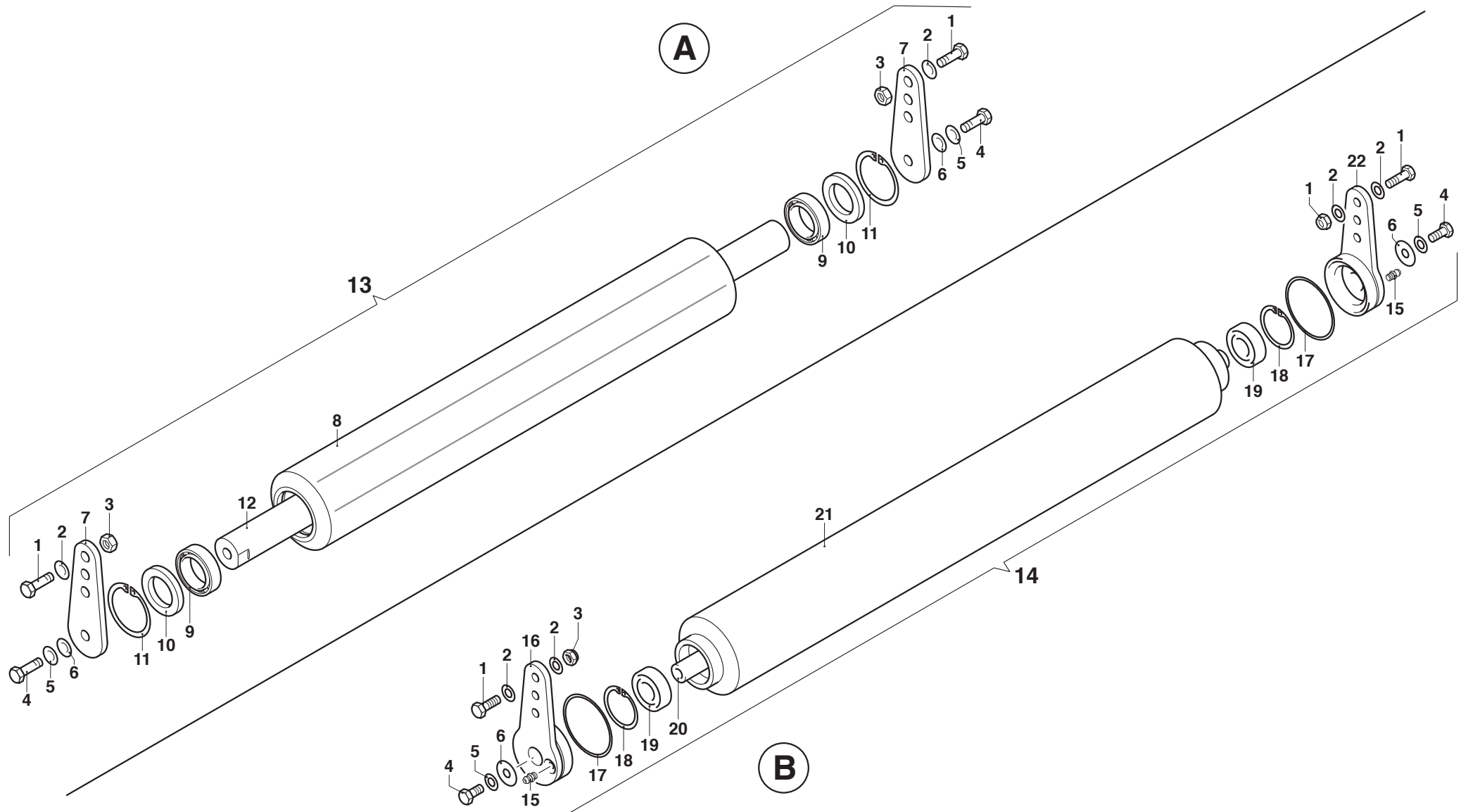

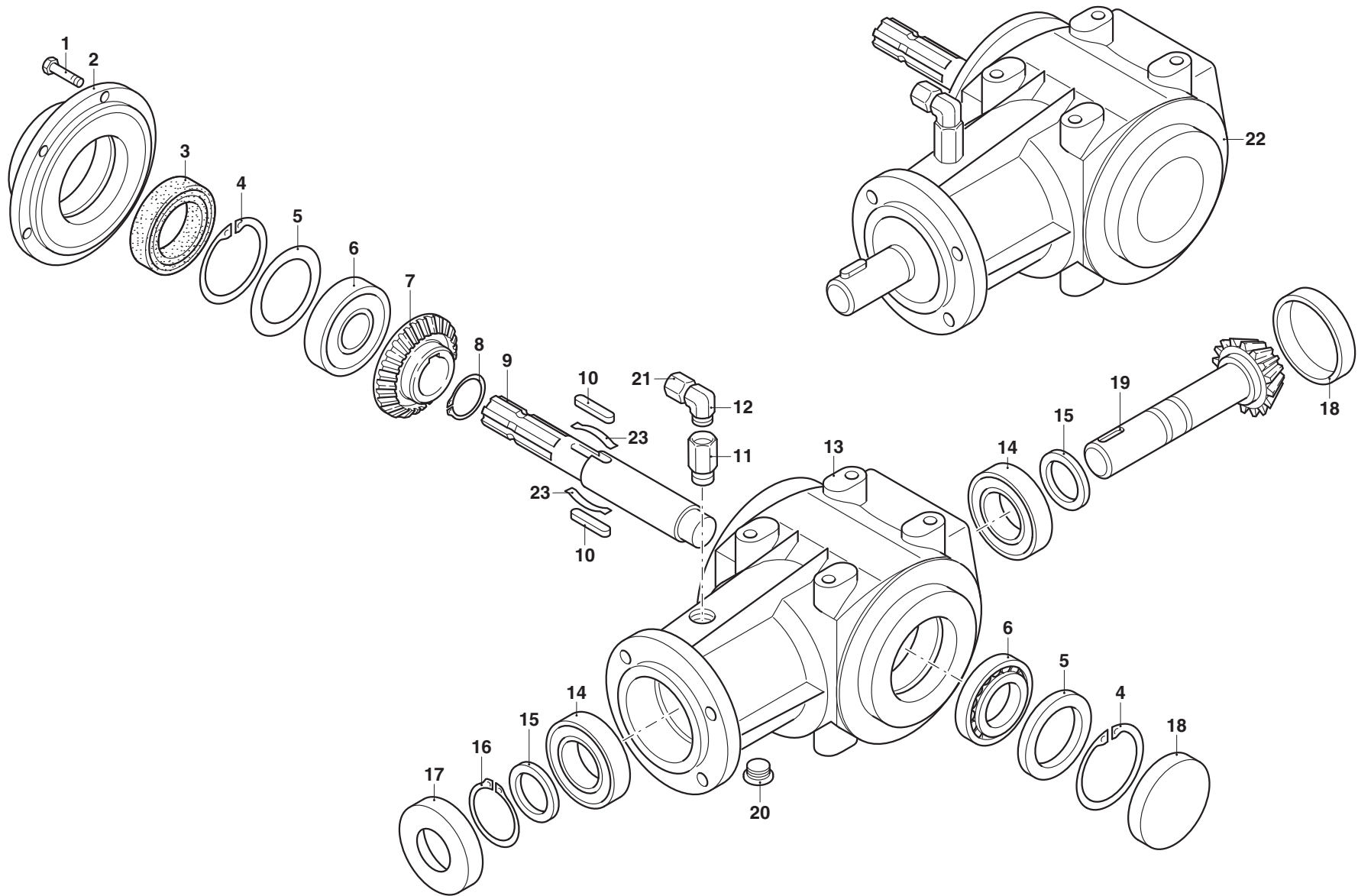

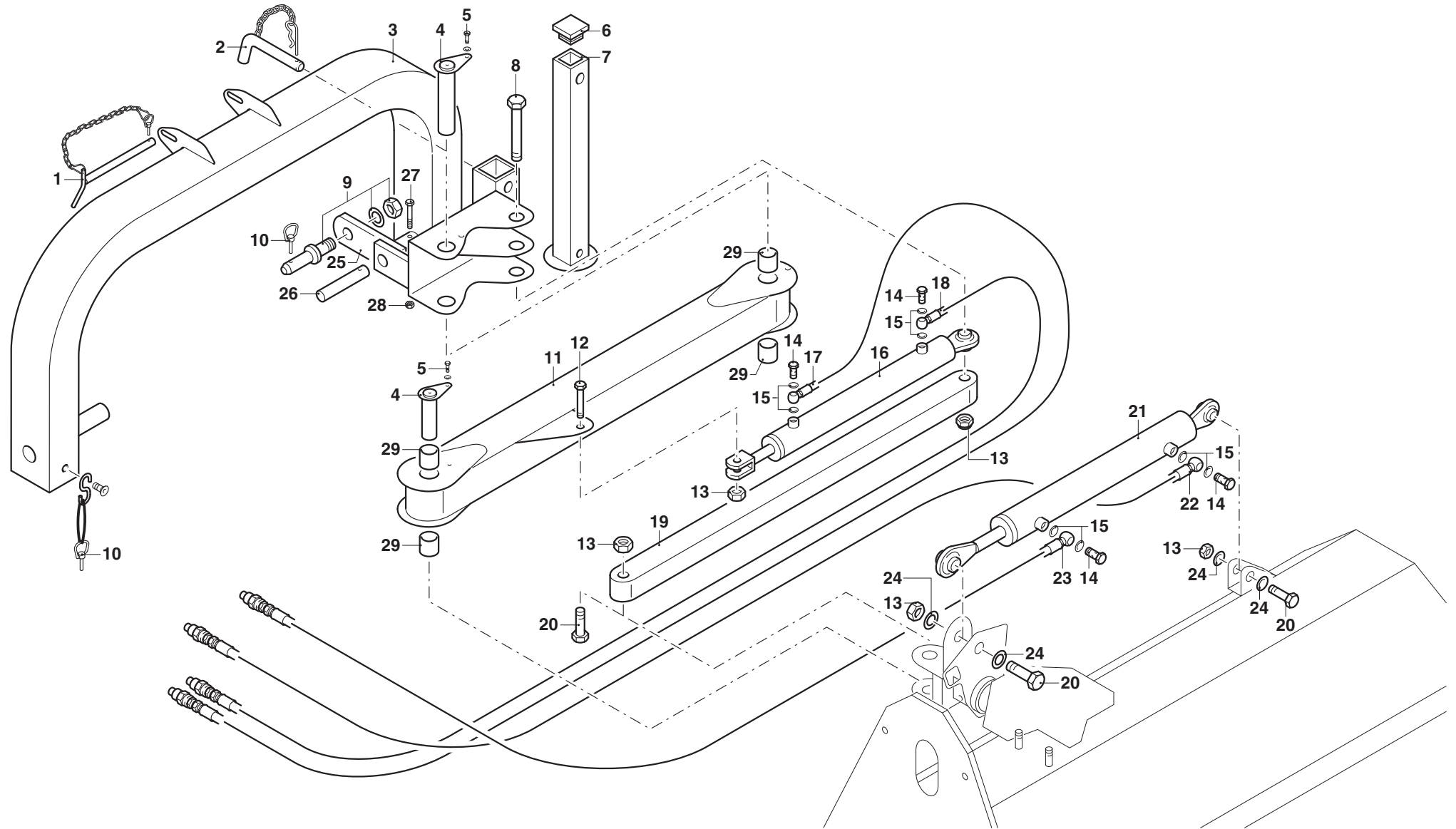

MURATORI MTL 2

TAV. 5.0

POS.	N° CODICE	Q.	DESCRIZIONE	DESIGNATION	BENENNUNG	DESCRIPTION	DESIGNAZIONE	Da matr. De nr. serie Vom Seriennr. From serial nr.	Fino matr. Jusqu'au nr. serie Bis Seriennr. Up to serial nr.
1	68062000	1	PERNO	PIVOT	BOLZEN	PIN			
2	68075300	1	PERNO	PIVOT	BOLZEN	PIN			
3	40298200	1	ARCATA	ARCADE	ARKADE	ARCADE			
4	68102300	2	PERNO	PIVOT	BOLZEN	PIN			
5	60020400	2	VITE	VIS	SCHRAUBE	SCREW	TE 12x25 UNI 5739		
6	68115000	1	TAPPO	BOUCHON	STOPFEN	PLUG			
7	40301400	1	PIEDE	PIED	FUSS	FOOT			
8	60045100	1	VITE	VIS	SCHRAUBE	SCREW	TE 20x160 UNI 5737		
9	68102200	1	PERNO COMPL.	PIVOT COMPLET	KOMPL. BOLZEN	COMPLETE PIN			
10	64001900	2	SPINA	GOUPILLE	STIFT	PIN	Ø10		
11	40301500	1	MONTANTE	MONTANT	SAEULE	PILLAR			
12	60026000	1	VITE	VIS	SCHRAUBE	SCREW	TE 20x50		
13	62004900		DADO	ECROU	MUTTER	NUT	M 20x2,5 AUTOBLOCC.		
14	60045200		VITE	VIS	SCHRAUBE	SCREW	FORATA 1/4"		
15	61007100		RONDELLA	RONDELLE	SCHEIBE	WASHER	RAME		
16	68102500	1	CILINDRO	CYLINDRE	ZYLINDER	CYLINDER			
17	68114600	1	TUBO	TUBE	ROHR	TUBE			
18	68114700	1	TUBO	TUBE	ROHR	TUBE			
19	40301600	1	STAFFA	BRIDE	BUEGEL	BRACKET			
20	60037500		VITE	VIS	SCHRAUBE	SCREW	TE 20x90 UNI 5739		
21	68102400	1	CILINDRO	CYLINDRE	ZYLINDER	CYLINDER			
22	68114800	1	TUBO	TUBE	ROHR	TUBE			
23	68114900	1	TUBO	TUBE	ROHR	TUBE			
24	61005800		RONDELLA	RONDELLE	SCHEIBE	WASHER	PIANA Ø20 UNI 6592		
25	30208000	1	STAFFA	BRIDE	BUEGEL	BRACKET			
26	68115400	1	PERNO	PIVOT	BOLZEN	PIN			

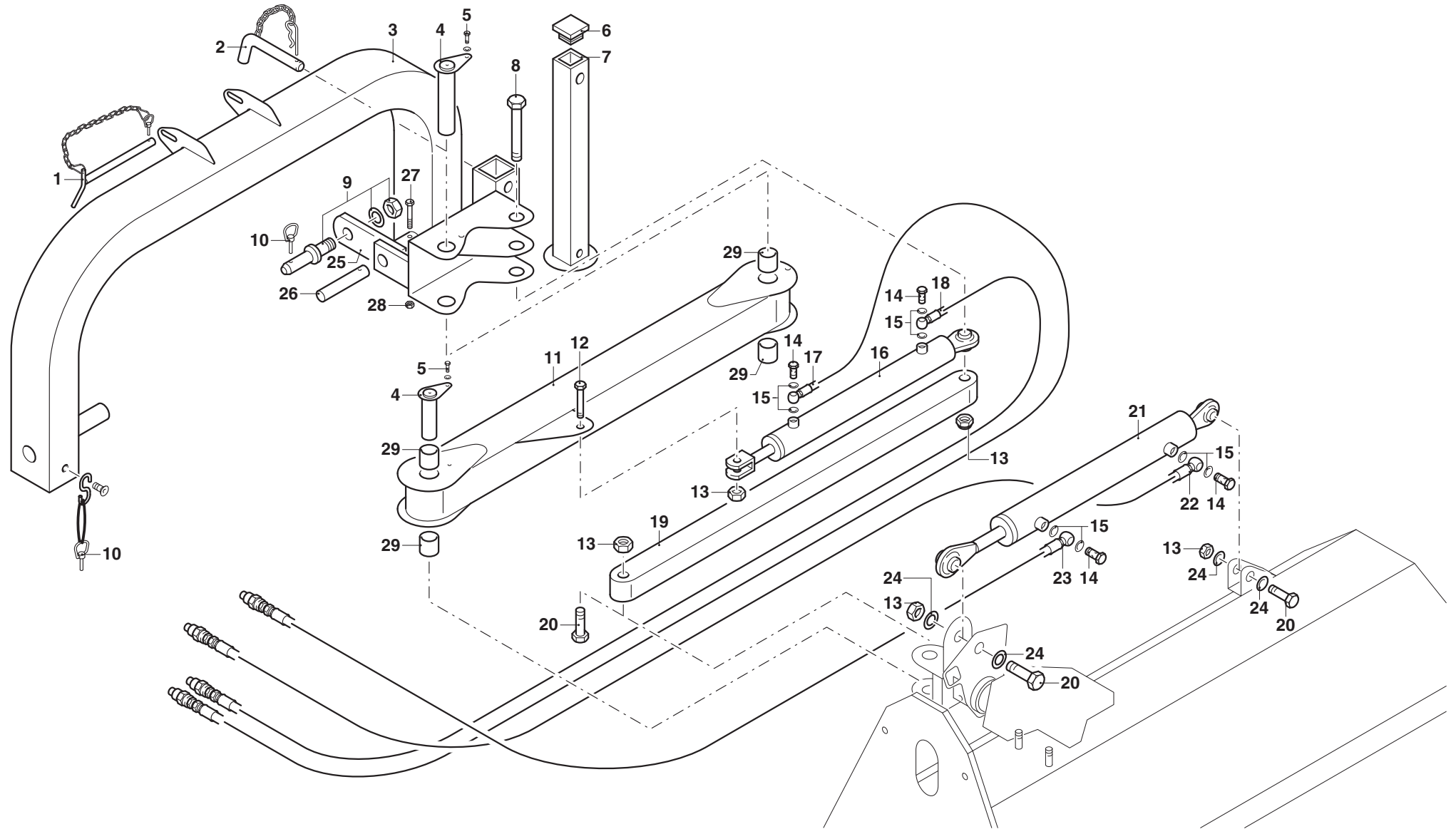



MURATORI S.p.A.

Via Pavarello, 21 - 41051 Castelnuovo Rangone (MO) Italy - Tel. 059.5330611 Fax 059.537259

www.muratoriequip.it info@muratoriequip.it

Capitale sociale Euro 480.000 interamente versato

Registro Imprese di Modena

Codice fiscale e numero d'iscrizione: 00708860366